

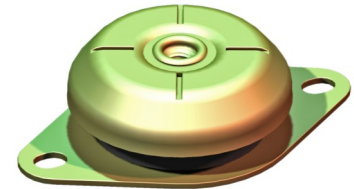

**GM-Mounting**  
**type 10-GM-500-A**  
**Max. 500 kg - 7 mm - 6 Hz**

**GM-Mountings** are very suitable for stationary and mobile applications. These compact anti-vibration mountings are easy to install and offer a high level of vibration and acoustic insulation. The integrated rebound control-device limits excessive movement under external loads. GM-Mountings are available in several rubber mixes to accommodate a large load range. These mountings can be supplied with a height adjustment feature and are also available with M12 inner thread.



Applications: generator sets, pump units, compressor sets, etc.

**LOAD CHARACTERISTICS**

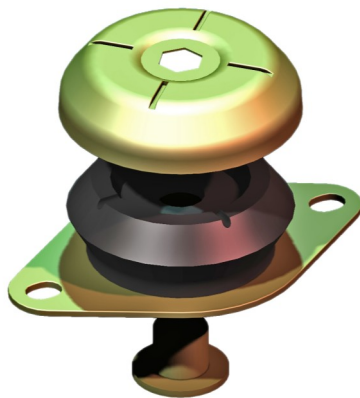
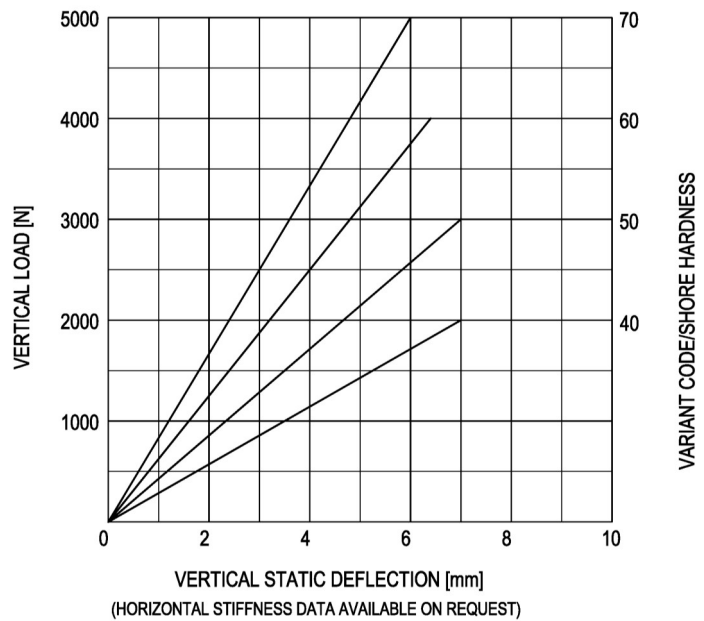

**SIDE-VIEW**

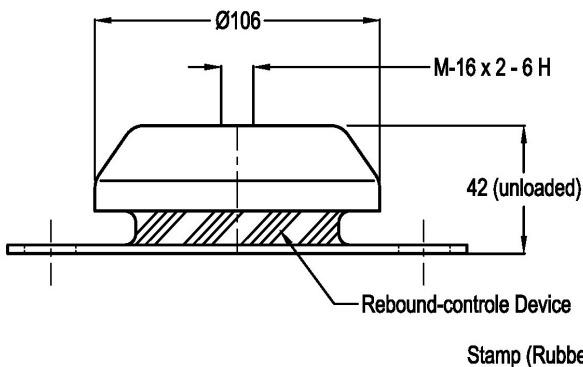

**TOPVIEW**

